

Razor *lite* LED

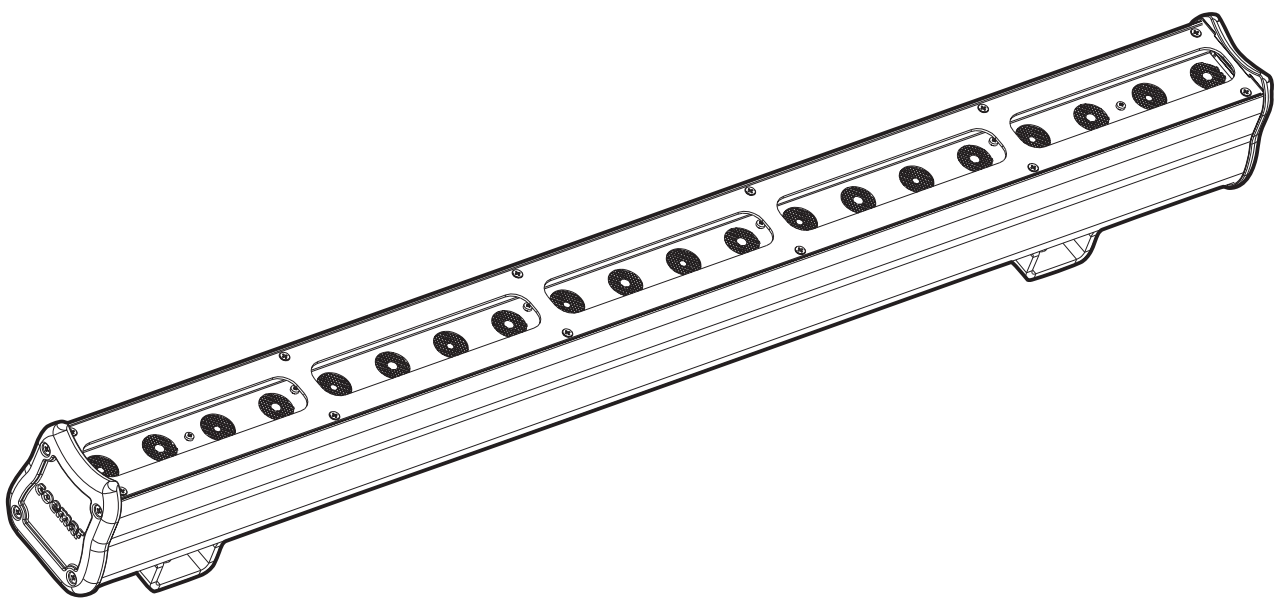

**manuale di istruzioni
instructions manual**

Version 1.0

 **coemar**
LIGHT EMOTION

Razor *Lite* LED

numero di serie/serial number

data di acquisto/date of purchase

fornitore/retailer

indirizzo/address

cap/città/suburb

provincia/capital city

stato/state

tel./fax/

Prendete nota, nello spazio apposito, dei dati relativi al modello e al rivenditore del vostro **Razor Lite Led** : questi dati ci permetteranno di assistervi con la massima rapidità e precisione.

*Please note in the space provided above the relative service information of the model and the retailer from whom you purchased your **Razor Lite Led**: this information will assist us in providing spare parts, repairs or in answering any technical enquiries with the utmost speed and accuracy.*

ATTENZIONE: la sicurezza dell'apparecchio è garantita solo con l'uso appropriato delle presenti istruzioni, pertanto è necessario conservarle.

WARNING: the security of the fixture is granted only if these instructions are strictly followed; therefore it is absolutely necessary to keep this manual.

English

try and in the technology used. We renew our invitation to you to complete the service information on the previous page, to expedite any request for service information or spares (in case of problems encountered either during, or subsequent to, installation). This information will assist in providing prompt and accurate advice from your **Coemar** service centre.. Following the instructions and procedures outlined in this manual will ensure the maximum efficiency of this product for years to come.

1. Packaging and transportation

1.1. Packaging

Open the packaging and ensure that no part of the equipment has suffered damage in transit. In case of damage to the equipment, contact your carrier immediately by telephone or fax, following this with formal notification in writing.

Packing list

Ensure the packaging contains:

- 1 **Razor Lite Led**
- 1 **Instruction manual**
- 2 **cam-lock support brackets**

1.2. Transportation

The **Razor Lite Led** should be transported in either its original packaging or in an appropriate flight case.

2. General information

2.1. Important safety information

Fire prevention:

- 1. Never locate the fixture on a flammable surface.
- 2. Minimum distance from flammable materials: 0.5 m.
- 3. Minimum distance from the closest illuminable surface: 0,5 m.
- 4. Replace any blown or damaged fuses only with those of identical values. Refer to the schematic diagram if there is any doubt.
- 5. Connect the projector to mains power via a thermal magnetic circuit breaker.

Prevention against electric shock:

- 1. High voltage is present in the internal of the unit. Isolate the projector from mains supply prior to performing any function which involves touching the internal of the unit.
- 2. For mains connection, adhere strictly to the guidelines outlined in this manual.
- 3. The level of technology inherent in the **Razor Lite Led** requires the use of specialized personnel for all service applications; refer all work to your authorized **Coemar** service centre.
- 4. A good earth connection is essential for proper functioning of the projector. Never operate the unit without proper earth connection.
- 5. The mains cable should not come into contact with other cabling.
- 6. Never handle the unit with wet hands or in a damp environment.

Safety:

- 1. The projector should always be installed with bolts, clamps, and other fixings which are suitably rated to support the weight of the unit.
- 2. Always use a secondary safety chain of a suitable rating to sustain the weight of the unit in case of the failure of the primary fixing point.
- 3. Never install the fixture in an enclosed area lacking sufficient air flow; the ambient temperature should not exceed 35°C.
- 4. The external surface of the unit, at various points, may exceed 80°C. Never handle the unit until at least 10 minutes have elapsed since the unit was turned off..

Protection rating of the body against liquids and solids (IP 65 version):

- 1. The fixture has an IP65 protection rating; this indicates that it is protected against dust and significant showers of water. This protection rating allows the fixture to be installed in an exposed location in inclement weather conditions.

2.2. Warranty conditions

- 1. The fixture is guaranteed for a period of 12 months against manufacturing faults and faulty materials.
- 2. Faults due to incorrect operation or operation in an inappropriate manner are not covered by the warranty.
- 3. The warranty is immediately void if the fixture has been operated or serviced by unqualified or unauthorised personnel.
- 4. The warranty does not include fixture replacement.
- 5. The model and serial numbers must be supplied for any warranty claims or advice from our authorised service personnel.

2.3. Certification



- 1. The fixture satisfies the essential requirements of the directive EMC 89/336/EEC, 93/68/EEC, BT73/23/EEC.
- 2. The fixture is in accordance with the standard EN 50419 (RoHS) and satisfies the requirements of the directive 2002/96/EC (WEEE).

3. Product specifications

3.1. Technical characteristics

Power:	90/240 Vac 50/60Hz Autosensing
Nominal current:	0.4A @ 230Vac 0,9A @ 115V
Power factor:	cos ϕ = 0.8
Led power:	36 Led x 1W
Minimum ambient temperature:	-15°C / 5°F
Maximum ambient temperature:	35°C / 95°F
Weight:	7.5 Kg / 16.5 lbs
IP Rating:	IP20 (standard version) IP65 (IP version)

3.2. Razor Lite Led dimensions

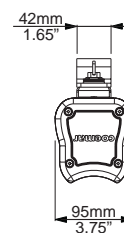
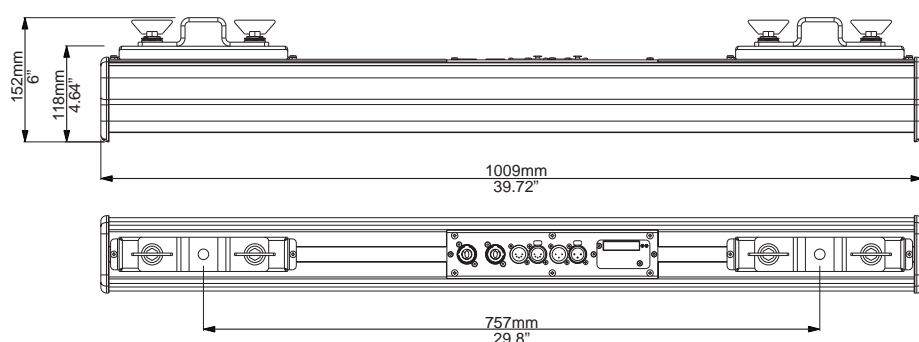

Versione Standard
Standard version

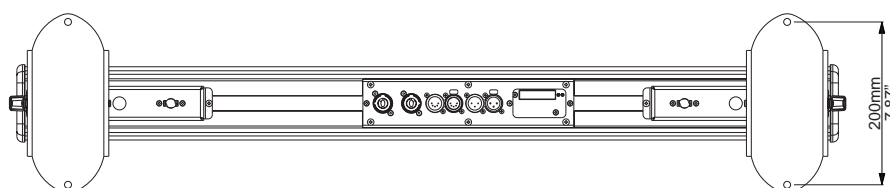

Versione con supporto
optional cod. 8052

Version with optional
support cod. 8052

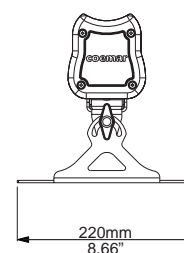
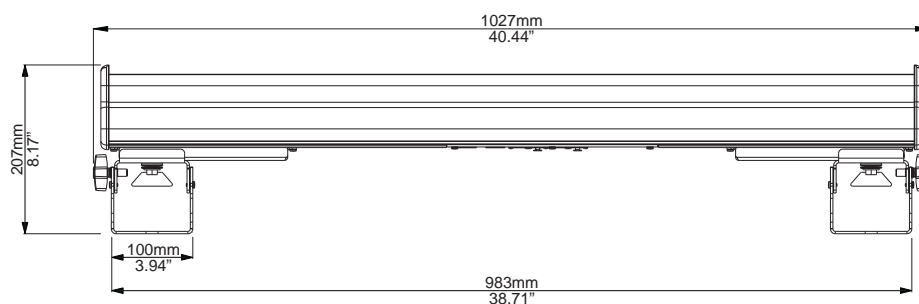

3.3. Projector components

The principal components of the **Razor Lite Led** are shown in the diagram below.

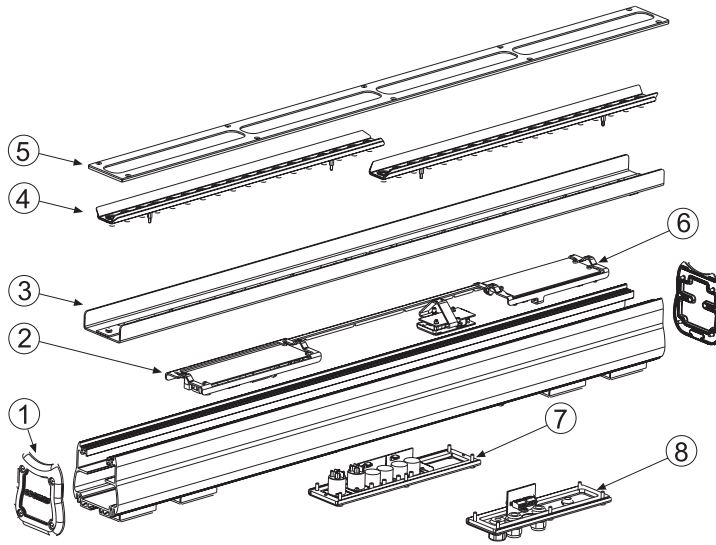

Components description

1. Side panel
2. Led control PCB
3. PCB group
4. Lens group
5. Front frame
6. Switching power supply
7. Back panel standard version
8. Back panel IP version

4. Installation

4.1. Mechanical installation

Razor Lite Led may be floor mounted or hung from an appropriate structure in any position.

Mobile installations

If hanging the fixture from a lighting truss or similar, we recommend the use of appropriate clamps "B", fixed to the fixture by the holes "A" provided, as shown in the following diagram.

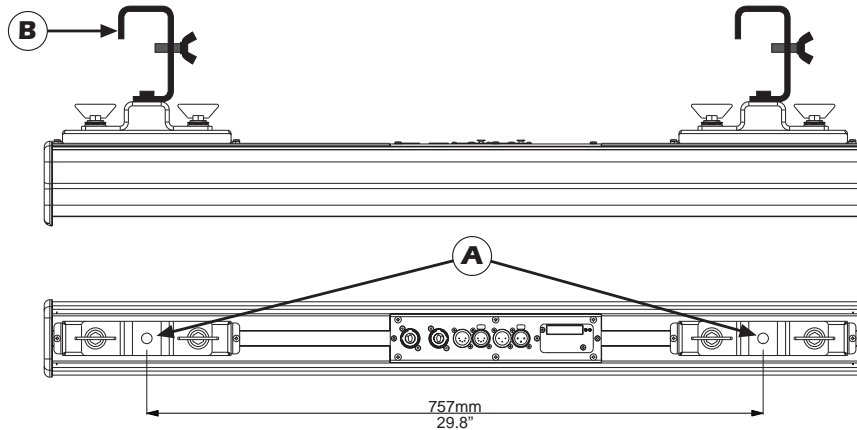

ATTENTION!!

Always ensure that your support structure and fixings (bolts, clamps, etc.) are rated to support the weight of the fixture.

Floor mounted installations

If the fixture is floor mounted, we recommend the use of appropriate clamps "C" (optional cod.8052), as shown in the following diagram.

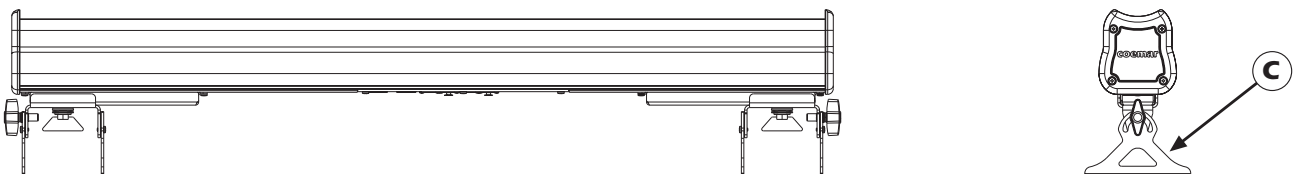

4.2. Safety chain

When hanging the **Razor Lite Led** we recommend the use of a safety chain "D" fixed to the yoke and to the suspension device. The safety chain should be either a metal wire rope or a metal chain, both appropriately rated for the purpose.

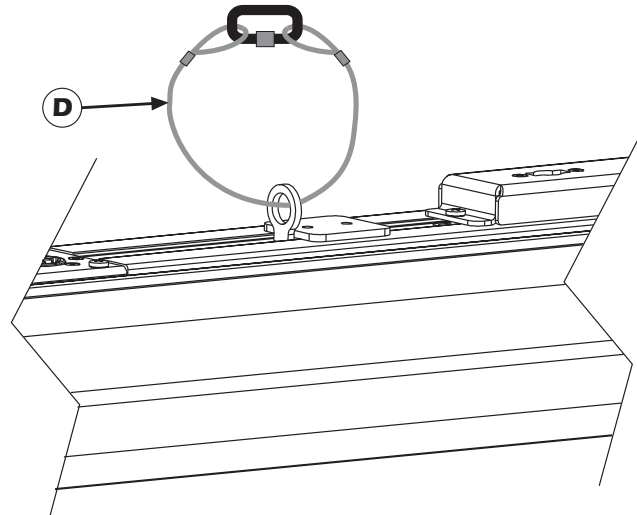

4.3. Adjusting beam direction

If the **Razor Lite Led** is floor mounted, it can be tilted to adjust the beam output. To perform this adjustment, follow the instructions set out below.

1. Loosen the handles "E" located on the side of the projector, thus allowing the inclination to be changed.

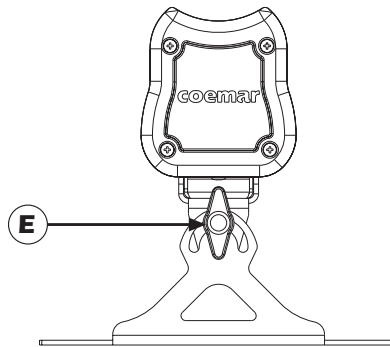

2. Adjust the projector's tilt.

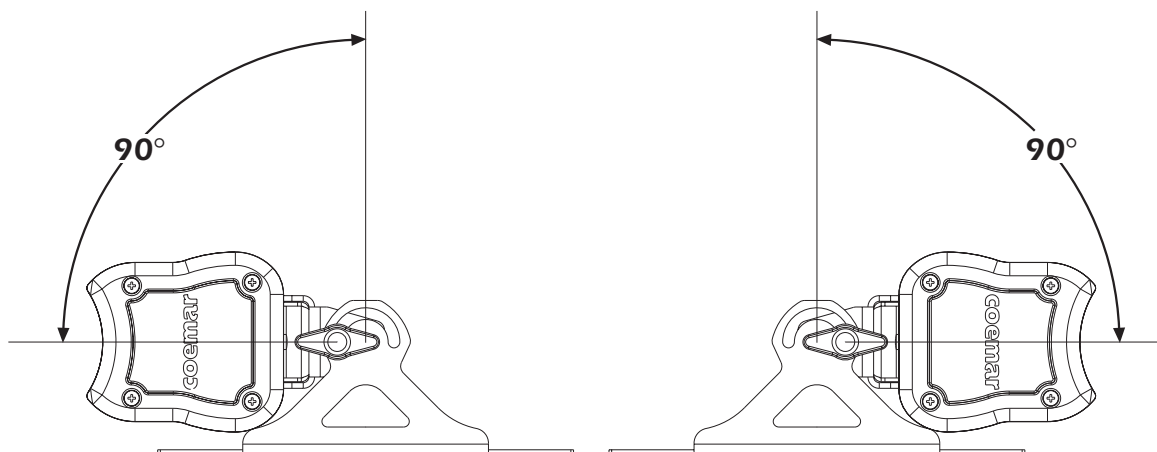

3. Refasten the handles "E" on the side of the projector.

English

4.4. Adjusting the beam angle

Three optical groups are available for **Razor Lite Led**. They are used to vary the beam dimension and make it suitable for different lighting applications.

The standard optical group, fitted on **Razor Lite Led**, is composed by a group of lenses that gives 6 X 10 beam angle. Here following you will find instructions to install different optical groups.

1. Remove the screws "F".

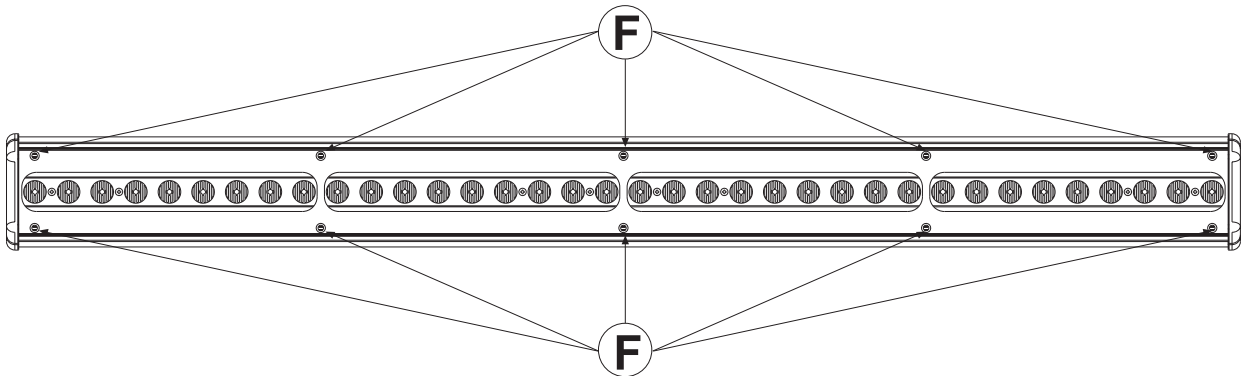

1. Remove the front frame "G" and the plexiglass "H".

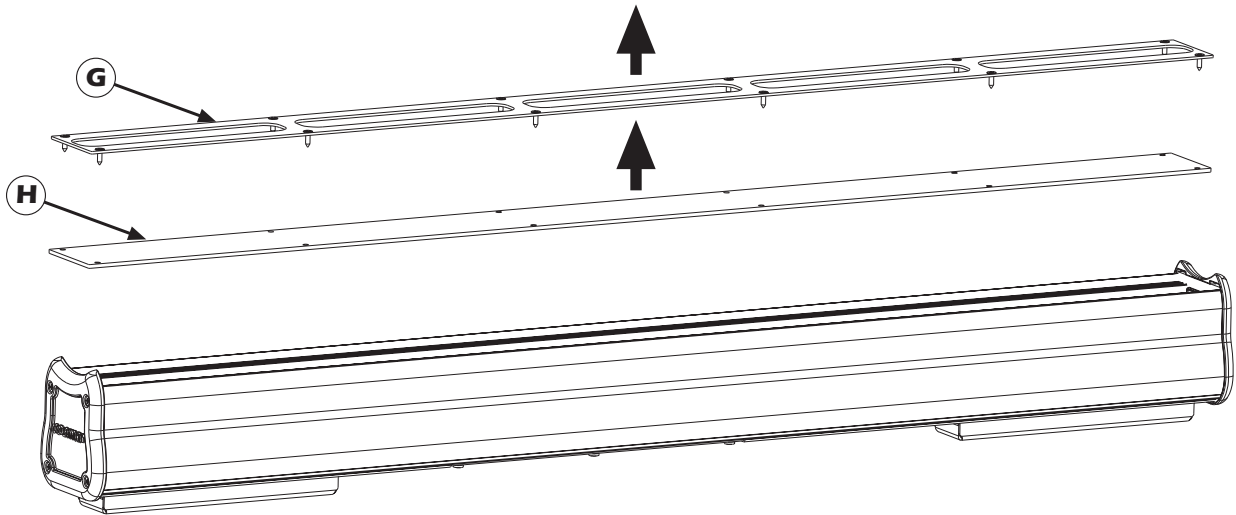

3. Remove the screws "L".

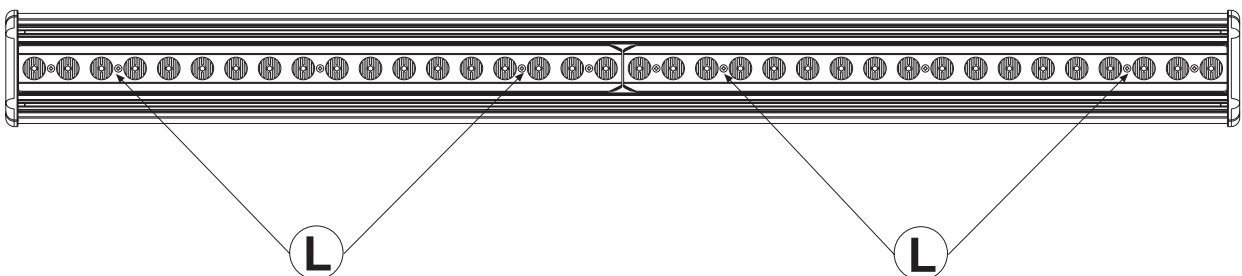

4. Replace the lenses "M" and ensure that the led fit perfectly in the lenses seats

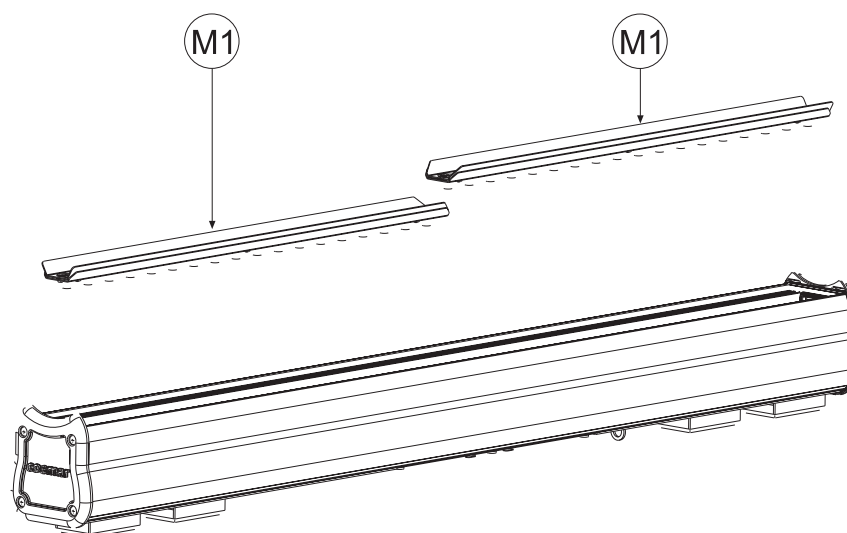

The optical groups must be placed with the trimmed angles inwards.

ATTENTION!!

The optical groups are asymmetrical. Pay attention to their assembly position.

5. Tighten the "L" fixing screws.
6. Insert the plexiglass "H" and the front frame "G" as per their original positions.
7. Tighten the "F" fixing screws.

The following table details the range of beam angle available for the **Razor Lite Led**.

Optical group	Beam angle
Elliptical lenses (standard, cod. GRLE08)	6 X 10
Narrow lenses (cod. GRLE09)	12°
Medium lenses (cod. GRLE10)	25°

4.5. Opening the fixture

In order to access the switch area on the IP version, fully unscrew the 6 mounting screws "N" and remove the panel from the fixture.

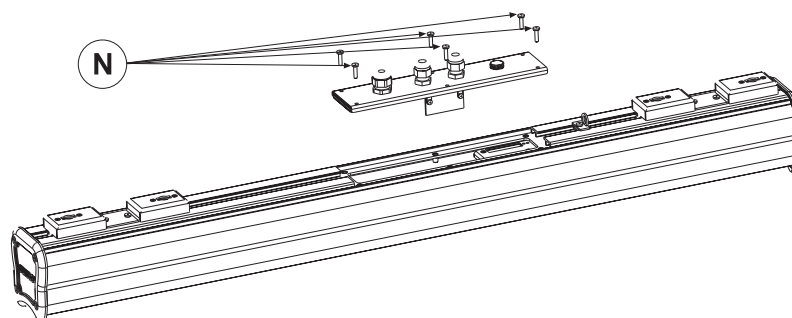

ATTENTION!!

Always remove main power prior to opening the fixture !
In the IP version, before closing the unit check that the garnishings are inserted in their places.
Screws "N" must be uniformly fixed, screwing them alternately in short steps.

5. Powering up

5.1. Operating voltage and frequency

The fixture may operate at voltages ranging from 90 to 250V AC at a frequency of 50 or 60 Hz.

It is not necessary to effect any setup procedures, Razor Lite Led will automatically adjust its operation to suit any frequency or voltage within this range.

5.2. Mains connection

Mains cable characteristics

The mains cable provided is thermally resistant, complying to the most recent international standards. It meets or exceeds VDE and IEC norms, IEC 331, IEC 332 3C, CEI 20 35.

NB: In case of cable replacement, similar cable with comparable thermal resistant qualities must be used exclusively (cable 3x1.5 \varnothing external 10 mm, rated 300/500V, tested to 2KV, operating temperature -40° $+180^{\circ}$, **Coemar** cod. CV5309).

Connection to mains power

Razor Lite Led is equipped with two power connectors, one as input and one as output, which can be used to connect more fixtures in series.

The maximum current absorbed from **Razor Lite Led** is indicated in the chart below:

- 230/240V 0,4 amps constant current in normal operation.
- 100/115V 0,9 amps constant current in normal operation.

The maximum working current of the connectors is **16A**.

ATTENTION!!

The absorption of the series of **Razor Lite Led** (I_{max}) can never be more than **16A**.

The maximum absorption I_{max} is given from the sum of the absorptions of all the **Razor Lite Led** connected in series.

Example:

For a series of 5 **Razor Lite Led** connected at 100V, $I_{max} = 0,9 \times 5 = 4,5A$

In the following figure you can see an example of series connection:

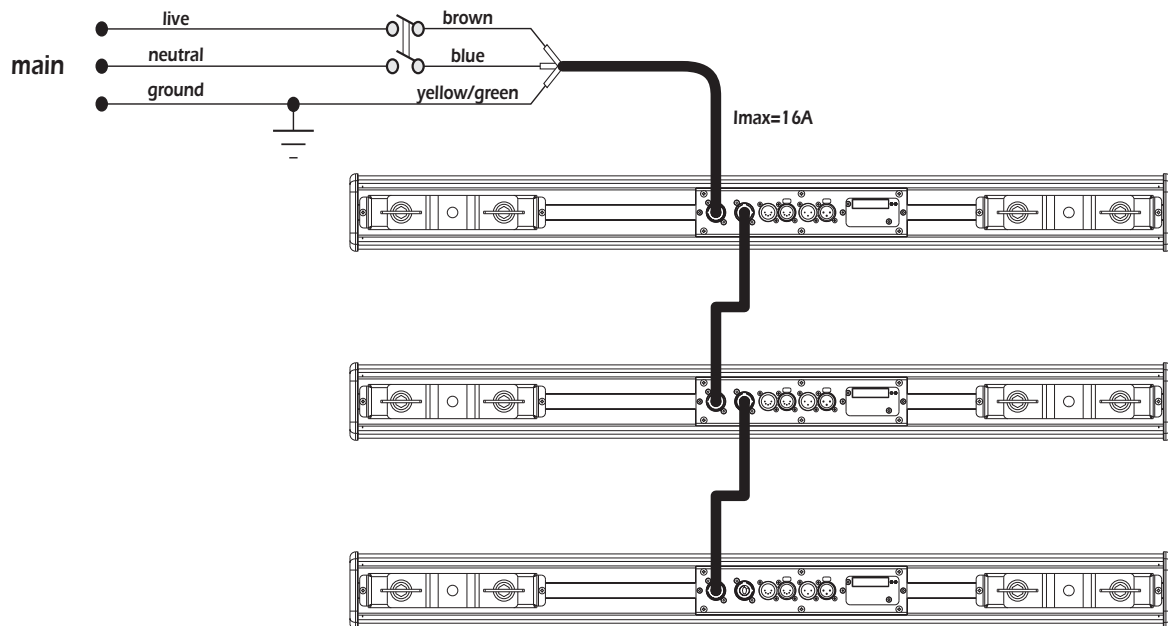

ATTENTION!!

- The use of a thermal/magnetic circuit breaker is recommended. Strict adherence to regulatory norms is strongly recommended.
- **Razor Lite Led** should not be powered through a Dimmer as this may damage the internal switching powersupply.
- Prior to connecting the device to mains power, ensure that the mains characteristics are within the recommended range for use with the **Razor Lite Led**.
- A good earth connection is essential for the corrected operation of the **Razor Lite Led**. Never install the unit unless the yellow/gree earth cable is securely connected.
- All cabling and connections should be carried out by suitably qualified personnel.

6. DMX signal functions

Razor Lite Led can operate in two modes:

1. using DMX512 control signal
2. automated "STAND ALONE" or "MASTER/SLAVE" modes (see chapter 9. AUTO function)

6.1. Connecting DMX signal

Control signal is digital and is transmitted via two pair screened cable, as recommended in international standards for the transmission of DMX512. Connection is serial, utilizing the XLR3 and XLR5 sockets located on the rear panel of the **Razor Lite Led**.

Signal connection via the XLR3 and XLR5 connectors

Connection is to international standards. Connection is as indicated below:

- pin 1 = GND
- pin 2 = data -
- pin 3 = data +

Should your DMX 512 controller output signal be through a cannon XLR5 (5 pin), pins 4 and 5 should remain unconnected.

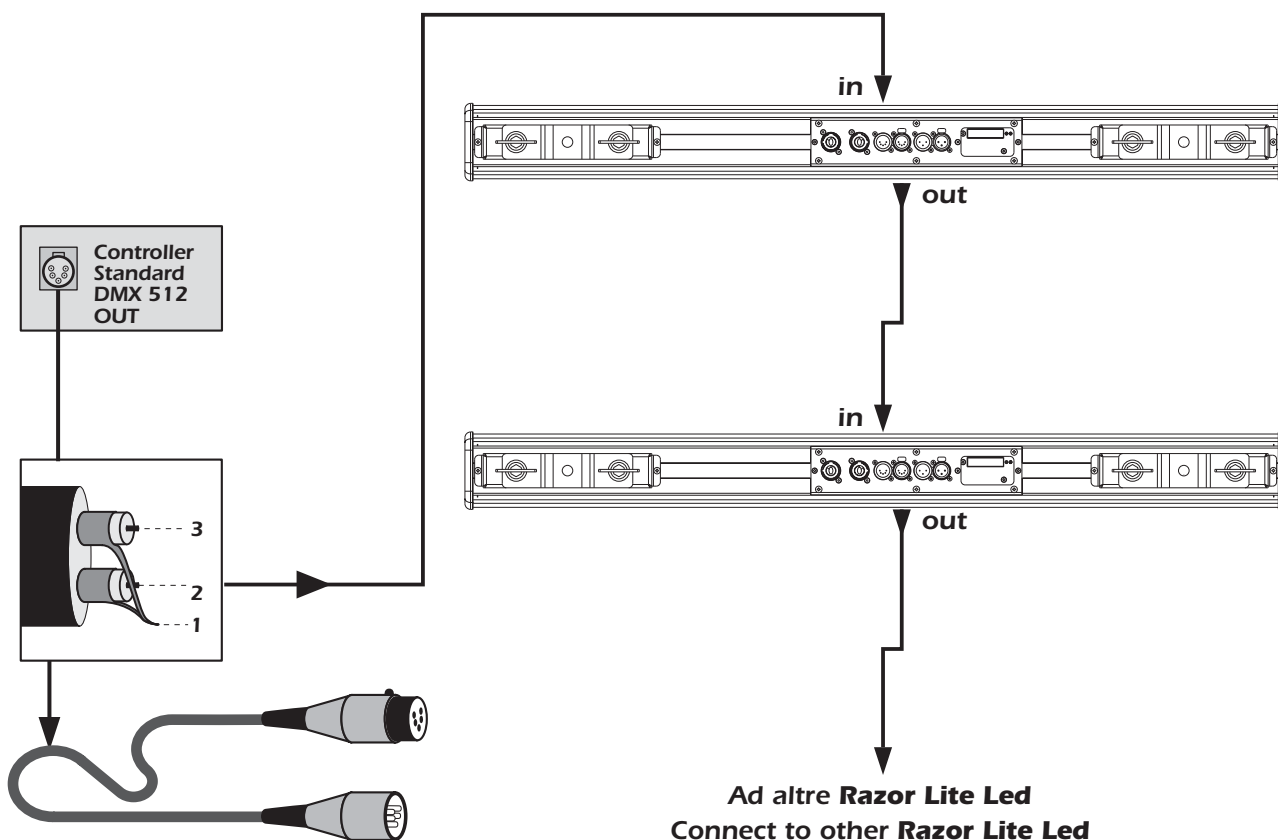

ATTENTION!!

Ensure that all data conductors are isolated from one another, the screening and the metal housing of the connector. Pin number 1 and the housing should never be connected to mains power.

6.2. Powering up

After having followed the preceding steps, turn on mains power on to the unit. The **POWER** led located near the dip-switch panel will come on.

Turning on power with DMX signal connected.

The yellow DMX led will flash to indicate that **DMX 512** is being correctly received. If the yellow led is off, DMX signal is not being received (see section 15. Frequently asked questions).

English

6.3. DMX addressing

Via the dip-switch panel, it is possible to assign a DMX address to the fixture. The address is determined by the sum of the values associated with the dip switches set to the on position.

Each unit can be set to use up to **6** address channels.

IMPORTANT NOTE: the following points are valid for all the instructions which follow.

1. Setting a dip-switch to the **ON** position activates its function
2. The **DMX** address may be altered without the need to turn the **Razor Lite Led** off.

The following are examples only for setting DMX addresses.

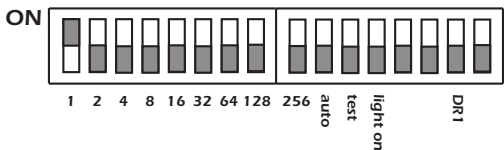
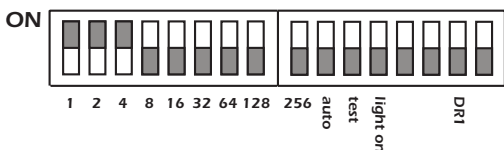
 <p>ON</p> <p>1 2 4 8 16 32 64 128 256 auto test light on DRI</p>	<p>Razor Lite Led number 1 Address DMX 001 is obtained by setting dip-switch 1 to the ON position</p>
 <p>ON</p> <p>1 2 4 8 16 32 64 128 256 auto test light on DRI</p>	<p>Razor Lite Led number 2 Address DMX 007 is obtained by setting dip-switches 1, 2 & 4 to the ON position</p>

6.4. DMX functions 6 channels

channel	function	type of control	effect	decimal	percentage
1	master dimmer	proportional	adjust luminous output intensity from 0 to 100%	0 - 255	0% - 100%
2	red	proportional	proportional control of the percentage of red colour from 0 to 100%	0 - 255	0% - 100%
3	green	proportional	proportional control of the percentage of green colour from 0 to 100%	0 - 255	0% - 100%
4	blue	proportional	proportional control of the percentage of blue colour from 0 to 100%	0 - 255	0% - 100%
5	no function	step	spare channel, allows the compatibility with Strip Lite Led	0 - 255	0% - 100%
6	strobe effect	step	noeffect	0 - 9	0% - 4%
		proportional	variable speed strobing effect, from slow to fast	10 - 57	4% - 22%
		step	stop strobe	58 - 59	23% - 23%
		proportional	sequenced pulse effect, slow closing, fast opening (variable speed pulsing, from slow to fast)	60 - 108	24% - 42%
		step	stop strobe	109 - 110	43% - 43%
		proportional	sequenced pulse effect, fast closing, slow opening (variable speed pulsing, from slow to fast)	111 - 159	44% - 62%
		step	stop strobe	160 - 161	63% - 63%
		proportional	random strobe effect with variable speed from slow to fast and synchronised colours	162 - 207	64% - 81%
		step	stop strobe	208 - 209	82% - 82%
		proportional	random strobe effect with variable speed from slow to fast and non-synchronised colours	210 - 255	82% - 100%

7. Test function

With the **TEST** dip-switch set to the ON position, **Razor Lite Led** will test each individual channel without the need for a DMX controller to be connected.

For example:

ON

1 2 4 8 16 32 64 128 256 auto test light on DR1

set the **TEST** dip-switch to **ON** on the **Razor Lite Led**.
The fixture will perform a quick sequential channel test

8. Light ON Function

Via this function the leds of the **Razor Lite Led** may be set to always on at a predetermined intensity.

When set to **ON** the dip-switch, illumination level and colour can be set by a combination of settings as shown in the table below.

dip-switch 1	dip-switch 2	Red
on	off	illumination level 30%
off	on	illumination level 60%
on	on	illumination level 100%
dip-switch 4	dip-switch 8	Green
on	off	illumination level 30%
off	on	illumination level 60%
on	on	illumination level 100%
dip-switch 16	dip-switch 32	Blue
on	off	illumination level 30%
off	on	illumination level 60%
on	on	illumination level 100%

Other examples of possible setting combinations are shown below.

ON

1 2 4 8 16 32 64 128 256 auto test light on DR1

LIGHT ON dip-switch set to **ON**
RED at 30% (dip-switch 1 set to **ON**)
GREEN at 100% (dip-switch 4 and 8 set to **ON**)
BLUE at 60% (dip-switch 32 set to **ON**)

ON

1 2 4 8 16 32 64 128 256 auto test light on DR1

LIGHT ON dip-switch set to **ON**
RED off
GREEN off
BLUE at 100% (dip-switches 16, 32 set to **ON**)

ATTENTION!!

Setting the Light ON dip-switch to active inhibits control via DMX signal.
The three colour dip-switches set to the OFF position turn off the colour.

9. Auto function

This function can be used to determine the operating mode of the projector (either **STAND ALONE** or **MASTER/SLAVE**), make program selections or alter the crossfade times. Setting this function to on inhibits control via DMX signal.

9.1. MASTER/SLAVE mode

In MASTER/SLAVE mode, it is possible to control, via a projector set as MASTER, a series of **Razor Lite Led** units set to act as SLAVE fixtures. The table below displays the settings required for fixtures to be connected in this manner.



MASTER	
<p>ON</p> <p>1 2 4 8 16 32 64 128 256 auto test light on DRI</p>	<p>Razor Lite Led set as MASTER running program 1</p>

To configure a **Razor Lite Led as MASTER** is simply a matter of setting the **Auto** dip-switch to the **ON** position and selecting a program for it to follow by making a selection from the following dip-switches: **1-2-4-8-256**. There are 4 programs which can be selected.

- dip switches **1-2-4-8** select programs 1, 2, 3, and 4 respectively.
- dip-switch **256** runs all four programs sequentially

ATTENTION!!

It is only possible to select one program at a time.

SLAVE	
<p>ON</p> <p>1 2 4 8 16 32 64 128 256 auto test light on DRI</p>	<p>Razor Lite Led set to SLAVE</p>

To configure a **Razor Lite Led as SLAVE** is simply a matter of setting the **Auto** dip-switch to the **ON**. **All** other dip-switches should be set to **OFF**.

Ad altri **Razor Lite Led SLAVE**
Connect to other **Razor Lite Led SLAVE**

After having selected the program you wish to run, dip-switches **16** and **32** may be used to set the wait time for each scene in the selected program. In this manner, programs can be made to run faster or slower according to your requirements. The following table outlines the dip-switch settings and their associated wait times.

time (wait time)		
dip-switch 16	dip-switch 32	
off	off	hold time 3 second
on	off	hold time 10 second
off	on	hold time 30 second
on	on	hold time 1 minute

Via dip-switches **64** and **128** it is possible to set the fade times for each scene in the selected program. The following table outlines the dip-switch settings and their associated fade times.

speed (fade time)		
dip-switch 64	dip-switch 128	
off	off	crossfade time 3 second
on	off	crossfade time 10 second
off	on	crossfade time 30 second
on	on	crossfade time 1 minute

The timing for each scene in a program is therefore a sum of the crossfade and hold times as set via these dip-switches. The following table gives an example of a possible setting.

<p>ON</p> <p>1 2 4 8 16 32 64 128 256 auto test led on DRI</p>	<p>Razor Lite Led set as a MASTER running program 3 hold time 30 sec. crossfade time 10 sec. Set the AUTO and 4 dipswitches to ON will select the fixture as MASTER running program 3. Setting dip-switch 16 to OFF and 32 to ON will set a hold time of 30 sec. Dip-switch 64 to ON and 128 to OFF will set a crossfade time of 10 sec.</p>
--	---

ATTENTION!!

When the AUTO function is selected the DMX signal reception is disabled to avoid system conflicts.

9.2. STAND ALONE mode

In **STAND ALONE** mode the projector operates independently with no need for DMX signal. It is possible to select the program which the projector runs and to alter the hold and crossfade times.

To configure the **Razor Lite Led** as **STAND ALONE** simply set dip-switch **Auto** to the **ON** position and select the program you wish to run and the hold and crossfade times to follow, as described in the previous section.

<p>ON</p> <p>1 2 4 8 16 32 64 128 256 auto test light on DRI</p>	<p>Razor Lite Led set as STAND ALONE running program 1</p>
--	--

10. DR1 function

ATTENTION!!

All the functions in this chapter are exclusively activatable from DR1.

This function allows for the transmission of bidirectional data with the **DR1** (cod. **CO9703**). Via the **DR1** (display remote) it is possible to remotely access, view and alter all the fixture's parameters and settings.

The **DR1** remote display unit allows the user to:

Monitor:

- 1) the current Software Version loaded
- 2) led operating life
- 3) projector operating life
- 4) presence and characteristics of incoming DMX 512
- 5) error messages
- 6) ID code
- 7) alarms

Edit and set:

- 1) DMX address
- 2) function mode

Execute:

- 1) Function test
- 2) Software update
- 3) Color alignment

To initiate communications with the **Razor Lite Led** the **DR1** must be installed into the DMX signal chain between the fixture and the controller following the instructions located internally on the unit.

The **DR1** dip-switch must be set to the **ON position**; from this point on, dip-switches 1 to 128 take on the task of assigning an identifying value (ID) to the fixture. They no longer set the fixture's DMX address, which is done by the **DR1**. The maximum number of unique IDs available in the **DR1** system is 250; dip-switch 256 has no functionality.

An example of a possible configuration is shown below:

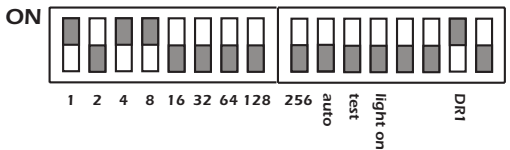
 <p>ON</p> <p>1 2 4 8 16 32 64 128 256 auto test light on DR1</p>	<p>Razor Lite Led RGB set to ID 13 and DR1 active configured by setting dip-switch DR1 to ON and dip-switches 1, 4 and 8 to ON</p>
--	---

10.1. Function modes using DR1 (MODE)

Using the inbuilt functionality of the **Razor Lite Led** via the **DR1**, it is possible to alter the function mode of the fixture. The following diagram illustrates the menu navigation system of the **DR1** in **MODE**.

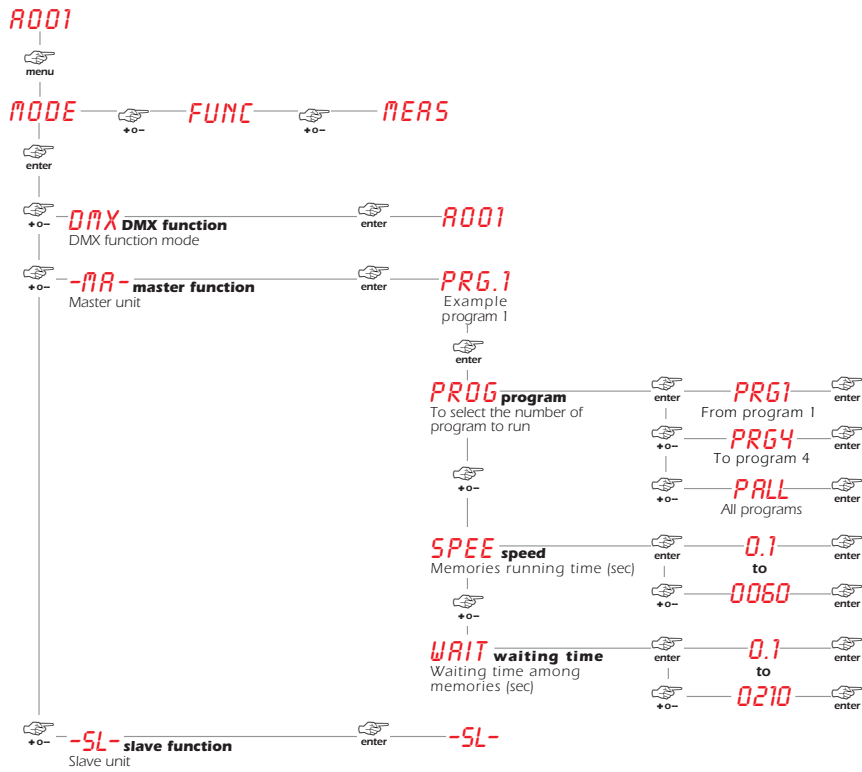

10.2. Setting up functionality via DR1 (FUNC)

Using the inbuilt functionality of the **Razor Lite Led** via the **DR1**, it is possible to alter the function settings of the fixture. The following diagram illustrates the menu navigation system of the **DR1** in **FUNC**.

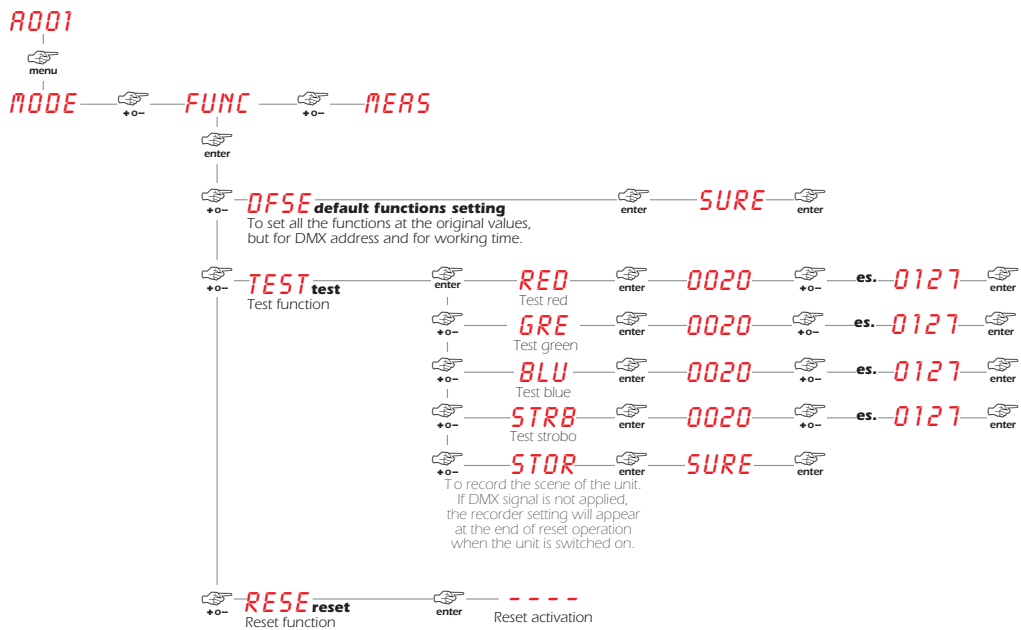

English

10.3. Diagnostic functions using DR1 (MEAS)

Using **MEAS** mode, it is possible to carry out several digital parameters checks and autodiagnosics. The following diagram illustrates the menu navigation system of the **DR1** in **MEAS**.

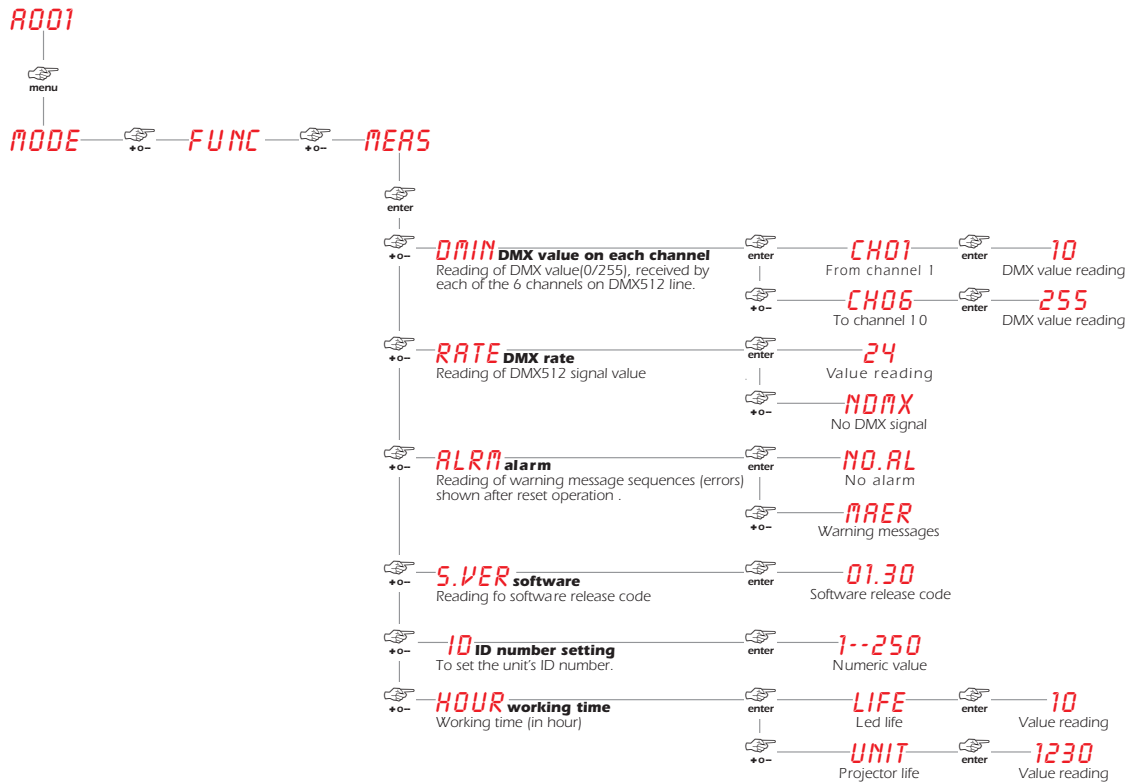

10.4. Electronic alignment and software upgrade

ATTENTION!!

This procedure should only be undertaken by qualified and experienced technical personnel..

The display panel of the **DR1** allows for the electronic alignment of the colors. This procedure is performed by **Coemar** at the factory. It may be useful to perform this procedure in the case of internal components being replaced (electronic parts). Altering the factory settings may radically alter the functioning of the projector. Carefully read all of the following prior to attempting any changes.

ATTENTION!!

The alignment procedure can only be carried out when DMX 512 signal is connected.

1. Press the **menu** button and then **enter** to confirm.
2. Press the **+** or **-** button until **FUNC** is displayed. Then press **enter**.
3. Press the **+** or **-** button until **RESE** is displayed.
4. Press the **enter** and **menu** buttons simultaneously, holding them for at least **10"**. The motors will perform a reset and the display will show **---** for a few seconds. After this, the display will show **ALIG** confirming that you have entered electronic calibration mode.

The following diagram illustrates the menu navigation system of the **DR1** in **ELECTRONIC ALIGNMENT**.

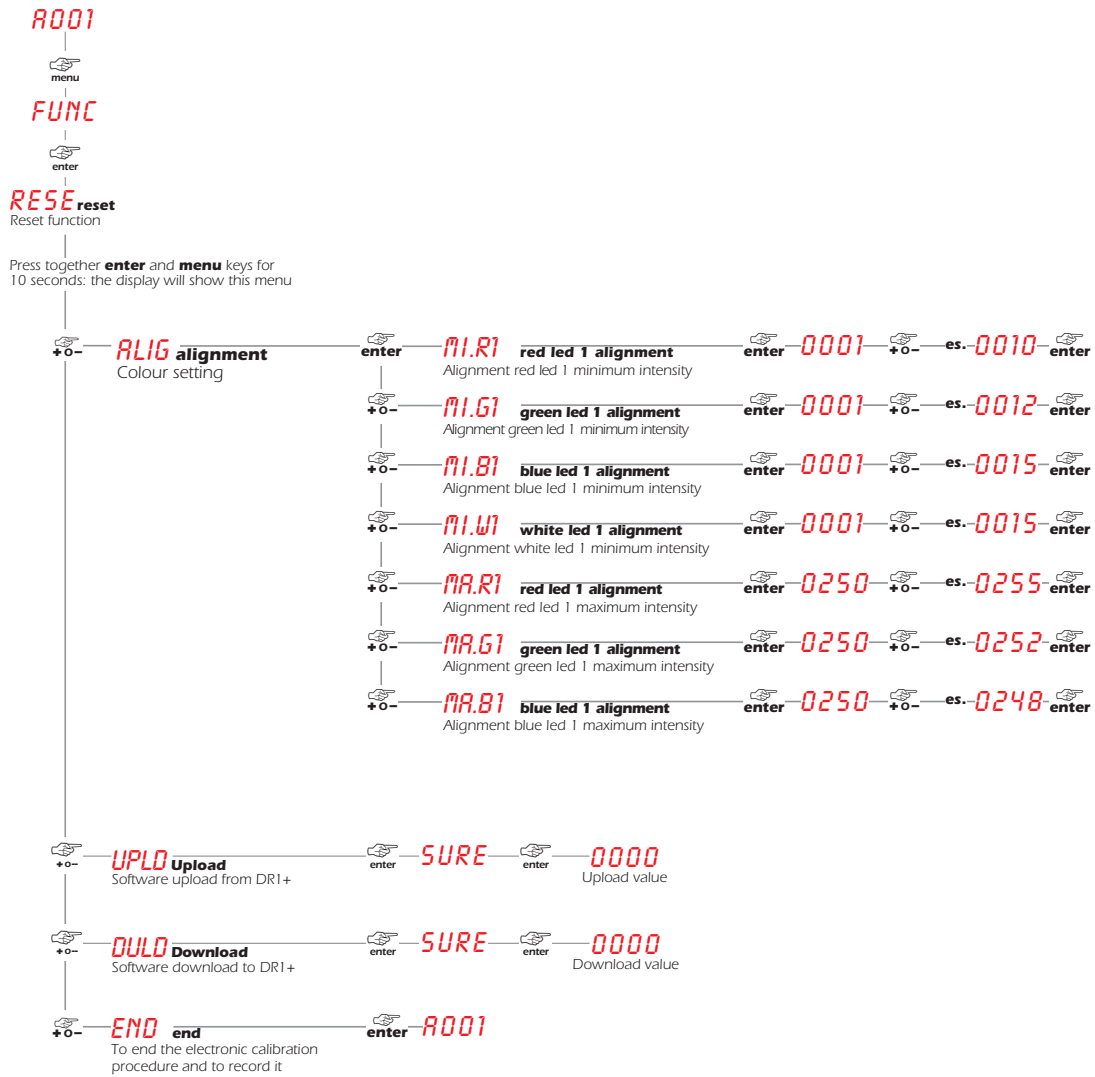

UPLOAD function

Using this function it is possible to upload software to the **Razor Lite Led** using a **DR1+**. For further information, consult the DR1 manual.

DOWNLOAD function

Using this function it is possible to download software from the **Razor Lite Led** to a **DR1+**. For further information, consult the DR1 manual.

English

10.5. Error messages using DR1

MESSAGE CODE	DESCRIPTION
<i>DTERR</i>	DATA Error The initial configuration settings are faulty or have been loaded incorrectly. The projector has loaded its default configuration. Turn the projector off and on again and if the error persists the EEPROM is either defective or absent; refer to your Coemar service centre for a replacement component.
<i>RDERR</i>	DMX ADDRESS Error The projector is not receiving all the DMX channels necessary for its operation. Check the DMX address and the control console operation. Note that some controllers may not generate all 512 channels of signal.
<i>MRERR</i>	MASTER MODE Error This message indicates that the user has attempted to set the unit to MASTER mode whilst DMX signal is still being received. Detach any DMX control signal or remove MASTER mode settings.

11. Switch panel signal

The two leds on the dip-switch panel indicate the functionality of the **Razor Lite Led**.

Led	Function	Led on	Led off	Led flashing
Green	Power	Present	Absent	Undefined
Yellow	DMX state	DMX poorly connected	No DMX signal	DMX OK

12. Maintenance

Whilst every possible precaution has been taken to ensure the trouble-free operation of your **Razor Lite Led**, the following periodic maintenance is highly recommended. We recommend that the voltage to the unit be removed prior to any maintenance procedure taking place.

ATTENTION!!

Always remove mains power prior to opening up the fixture!

12.1. Fuse replacement

Use a multimeter to check the fuse, replacing any faulty or damaged fuses with ones of equal value, dimensions and characteristics. The following diagram indicates the positioning and characteristics of the protection fuse in the fixture.

Fuse A: 3A F 250V

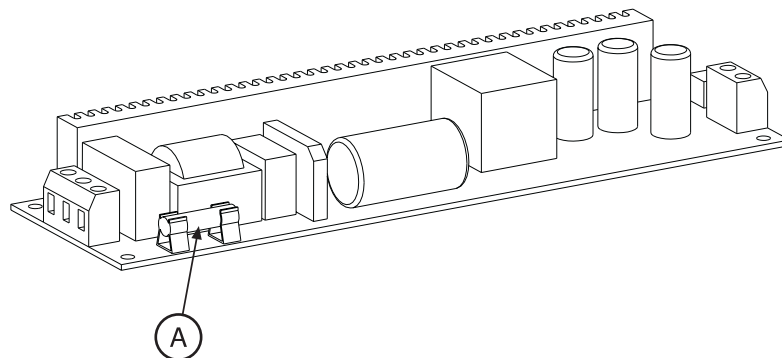

12.2. Periodic maintenance

Mechanicals

Check that the units is not mechanically damaged. Regularly clean the glass by using a soft cloth with a specific cleaning liquid and, if necessary, replace the damaged parts.

Electrical components

Check all electrical components for correct earthing, oxidation and proper attachment of all connectors, cleaning and refastening if necessary.

13. Spare parts

All the components of the **Razor Lite Led** are available as spare parts from your **Coemar service centre**.

Accurate description of the fixture, model number, and type will assist us in providing for your requirements in an efficient and effective manner.

14. Available accessories

Item	Code
Floor mounting	cod. CO8052
Filter holder	cod. CO8055/4

15. Frequently asked questions

The diagram below indicates some possible problems and solutions if they should occur.

Problem	Possible solution
Razor Lite Led won't turn on.	Mains power is not available to the Razor Lite Led : - Check that the green Led is on, if so check the incoming voltage to the Razor Lite Led . - Check the main pcb fuse and that of the switching powersupply.
Razor Lite Led doesn't respond to DMX signal	Incoming DMX may not be being received by the Razor Lite Led : - Check that the led indicating DMX input is flashing. If not, check the DMX console's output and any cabling for continuity. - Check the dip-switch panel to ensure that no functions are selected which inhibit DMX control . - Razor Lite Led may be incorrectly addressed. Check the DMX addressing.
The Razor Lite Led is set to auto but is not running any programs	In addition to setting the AUTO dip-switch to on, it is necessary to also select a program number (see section 9. AUTO function). - Multiple programs have been selected - only one program at a time may be selected. - Check that amongst the interconnected fixtures, only one has been set to Master. - Ensure that there is no incoming DMX signal (this may cause a conflict in signals).



Coemar s.p.a.

via Inghilterra 2/A - 46042 Castel Goffredo (Mantova) Italy
ph. +39 0376/77521 - fax +39 0376/780657
info@coemar.com

Coemar si riserva il diritto di apportare modifiche senza preavviso.
Coemar reserves the right to effect modifications without notification